

TRAILS B6T

LOUDSPEAKERS

Concealable Subwoofer



USER MANUAL

INDEX

1.	IMPORTANT REMARK	3
2.	IMPORTANT SAFETY INSTRUCTIONS	4
3.	IMPORTANT NOTE	6
4.	INTRODUCTION	6
5.	MAIN SPECIFICATIONS	6
6.	CONNECTION	7
7.	LOCATION AND INSTALLATION	8
	<i>6.1 Procedure for installation in a suspended ceiling</i>	<i>9</i>
	<i>6.2 Flat surface installation procedure</i>	<i>10</i>
	<i>6.3 Procedure for installation behind a partition wall</i>	<i>11</i>
8.	TECHNICAL SPECIFICATIONS	12
9.	CONTENTS OF PACKAGING	12

1. IMPORTANT REMARK



WARNING: SHOCK HAZARD - DO NOT OPEN

AVIS: RISQUE DE CHOC ÉLECTRIQUE - NE PAS OUVRIR



The lightning flash with arrowhead symbol, within an equilateral triangle, is intended to alert the user to the presence of uninsulated “dangerous voltage” within the product’s enclosure that may be of sufficient magnitude to constitute a risk of electric shock to persons.



The exclamation point within an equilateral triangle is intended to alert the user to the presence of important operating and maintenance (servicing) instructions in the literature accompanying the appliance.

WARNING: To prevent fire or shock hazard, do not expose this equipment to rain or moisture.

WARNING: An apparatus with Class I construction shall be connected to a mains socket-outlet with a protective earthing connection.

2. IMPORTANT SAFETY INSTRUCTIONS

1. Read these instructions.
2. Keep these instructions.
3. Heed all warnings.
4. Follow all instructions.
5. Do not use this apparatus near water.
6. Clean only with dry cloth.
7. Do not block any ventilation openings. Install in accordance with the manufacturer's instructions.
8. Do not install near any heat sources such as radiators, heat registers, stoves, or other apparatus (including amplifiers) that produce heat.
9. Do not defeat the safety purpose of the polarized or grounding type plug. A polarized plug has two blades with one wider than the other. A grounding type plug has two blades and a third grounding prong. The wide blade or the third prong are provided for your safety. If the provided plug does not fit into your outlet, consult an electrician for replacement of the obsolete outlet.
10. Protect the power cord from being walked on or pinched particularly at the plugs, convenience receptacles, and at the point where they exit from the apparatus.
11. Only use attachments/accessories specified by the manufacturer.
12. Unplug the apparatus during lightening sorts or when unused for long periods of time.
13. Refer all servicing to qualified personnel. Servicing is required when the apparatus has been damaged in any way, such as power supply cord or plug is damaged, liquid has been spilled or objects have fallen into the apparatus, the apparatus has been exposed to rain or moisture, does not operate normally, or has been dropped.
14. Disconnecting from mains: Switching off the POWER switch all the functions and light indicators of the amplifier will be stopped, but fully disconnecting the device from mains is done unplugging the power cord from the mains input socket. For this reason, it always shall remain readily operable.
15. Equipment is connected to a socket-outlet with earthing connection by means of a power cord.
16. The marking information is located at the bottom of apparatus.
17. The apparatus shall not be exposed to dripping or splashing and that no objects filled with liquids, such as vases, shall be placed on apparatus.

NOTE: *This equipment has been tested and found to comply with the limits for a Class A digital device, pursuant to part 15 of the FCC Rules. These limits are designed to provide reasonable protection against harmful interference when the equipment is operated in a commercial environment. This equipment generates, uses, and can radiate radio frequency energy and, if not installed and used in accordance with the instruction manual, may cause harmful interference to radio communications. Operation of this equipment in a residential area is likely to cause harmful interference in which case the user will be required to correct the interference at his own expense.*



WARNING: This product must not be discarded, under any circumstance, as unsorted urban waste. Take to the nearest electrical and electronic waste treatment centre.

NEEC AUDIO BARCELONA, S.L. accepts no liability for any damage that may be caused to people, animal or objects due to failure to comply with the warnings above.

3. IMPORTANT NOTE

Congratulations. You now possess the result of careful design and meticulous manufacturing. We are very grateful for your trust in purchasing our TRAILS6T concealable subwoofer.

In order to obtain maximum effectiveness and performance, it is VERY IMPORTANT, prior to connection, to carefully read and to take into account the instructions given in this manual. To guarantee optimum operation, we recommend that all maintenance be carried out by our authorised Technical Services.

4. INTRODUCTION

TRAILS6T is intended as a bass reinforcement and is constructed of wood, with a very compact design. It incorporates a 6.5-inch, 60 Wrms, 8 Ω driver, a transformer with four selectable powers for use in 70/100 V lines and an internal low-pass filter.

It has been specially designed to meet the requirements of a permanent installation, in which low visual impact and integration with its surroundings are essential: concealed in suspended ceilings and on surfaces, etc. Installation accessories are included. Available in black

5. MAIN SPECIFICATIONS

- Small-format, sub-bass woofer enclosure made of wood, for strengthening TRAIL 103 type or other loudspeaker in ceilings or other small-format boxes
- Externally-selectable low-pass filter: 150 Hz / OFF
- Suitable for 70/100 V and low-impedance lines
- Power selector 60/30/15/7.5 W and 8 Ohms
- Euroblock input connector
- Can be installed in suspended ceilings, partition walls or on walls, etc.
- Support for suspended ceilings and grille included
- Installation system included
- Available in black

6. CONNECTION

The TRAILS6T operates into high or low impedance. For this reason, it has a rear panel fitted with a 5-position switch for operating-mode selection. The first four positions enable the system to operate into high impedance mode, and the fifth is for low impedance.

The four positions of the power selector for the 70/100 V line allow the maximum-power configuration at which each unit operates. Therefore, the lower positions are used in areas requiring low SPL (7.5 W or 15 W) and the upper positions are for areas requiring higher levels (30 W or 60 W).

Note: if the loudspeaker is used in 70V installations, the corresponding powers for the 100V position will be reduced to half those indicated on the switch. To one quarter for 50V installations.

The fifth position corresponds to low-impedance operation (8Ω) and a maximum power of 60 W. If this setup is adopted, consideration must be given to amplifier limits when several loudspeakers are connected to its output, especially if the overall impedance is below 4Ω . Furthermore, it is important that the cable connecting the amplifier outputs to the loudspeakers is of good quality and as short as possible; this is of special significance when long distances have to be covered and loudspeaker impedance is low.

Note: The loudspeaker distribution along a 70/100V line historically arises from the technical requirement to mix loudspeakers of different impedances and/or powers on the same amplification line or channel, but without any need to worry about the total impedance of the full assembly. Moreover, this solution enables long cable runs with significantly smaller sections than those usually employed in low-impedance installations, but with minimum power losses.

WARNING! If the system is accidentally connected with the switch in the 100 V/60 W position to a low-impedance amplifier, no damage will be caused to the loudspeaker, but its performance will be well below its specifications. If the loudspeaker is accidentally connected to a 70 V/100 V network, in the 8Ω position, it will be seriously damaged.

7. LOCATION AND INSTALLATION

TRAILS6T provides various installation systems. The packaging contains all the accessories required for the various options. Installation in suspended ceiling, on a flat surface (wall or ceiling) and behind partition walls.

In general, the following rules will be followed:

- The unit must always be installed on firm, solid surfaces when the installation is on a flat surface (wall or ceiling).
- Suspended ceiling installation: TRAILS6T can be installed in suspended ceilings with 60 cm wide profiles.
- For good sound reproduction, there must not be any obstacles between the loudspeaker and the audience.
- The sound-pressure levels must be adapted to the reproduction needs. Despite its reduced size, TRAILS6T provides a much higher performance than domestic loudspeakers.

Note: the TRAILS6T loudspeaker may be adapted in several ways to your needs by means of the supplied installation accessories. The procedures described in this manual are examples, but there are other installation options that can be executed by following the instructions in this manual; at corners, walls with angles, on the floor, concealed in furniture, etc.

6.1 Procedure for installation in a suspended ceiling

Before commencing with the securing of the metal fittings, consideration must be given to the coupling bar because a 68 mm hole must be made in the ceiling for its installation and that of the trim grille.

1. Screw the metal fittings to the TRAILS6T using the supplied screws. This can be executed by using several of the holes in the supports for the coupling bar installation in the desired position. See figure 1.
2. Execute a 68 mm hole for the coupling bar in the suspended ceiling.
3. Check that the system is stable and then carry out the necessary connections and adjustments before installing it over the suspended ceiling.
4. Install the loudspeaker with the metal fittings already in place over the suspended ceiling and leave the system resting on the profiles.
5. Install the coupling bar with the trim grille, passing it through the 68 mm hole. Push the bar towards the loudspeaker until the grille is flush with the suspended ceiling.

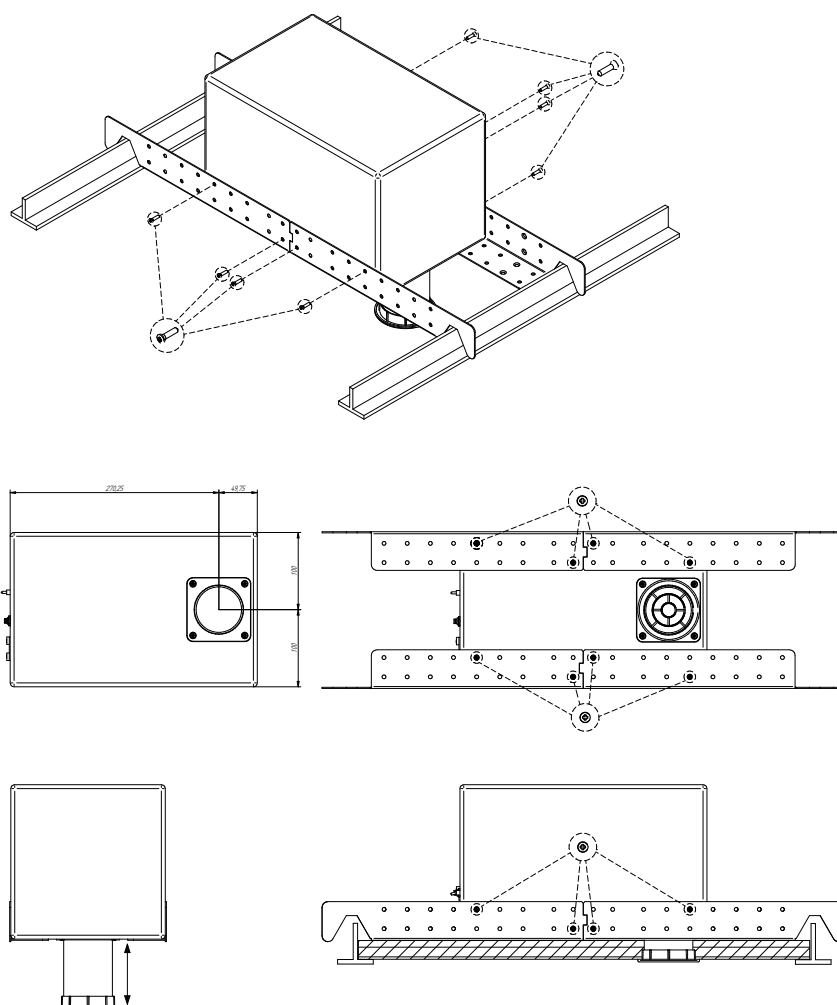

Figure 1: diagram for suspended ceiling installation

6.2 Flat surface installation procedure

1. Screw the lower metal fitting to the wall at the required height. Remember that the lower part of the TRAILS6T will rest on this angle. See figure 2.
2. Check that the system is stable and then carry out the necessary connections and adjustments before installing the upper support.
3. Screw the upper support to the TRAILS6T with the supplied screws (Figure 2) and then screw it to the wall, leaving the loudspeaker resting on the lower support.
4. Lastly, secure the TRAILS6T to the lower support using the supplied screws.

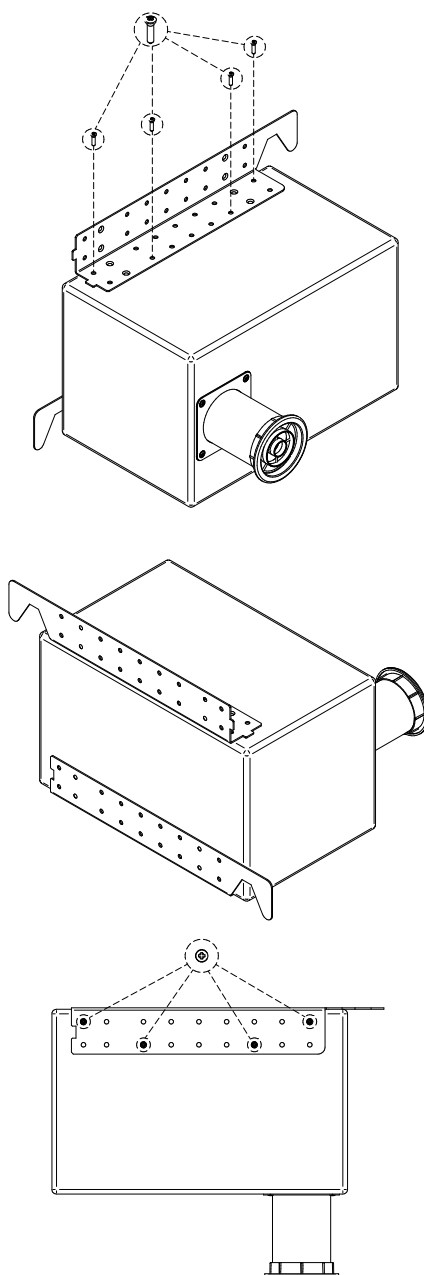

Figure 2: diagram of wall installation

6.3 Procedure for installation behind a partition wall

1. Before commencing with the securing of the metal fittings, consideration must be given to the coupling pipe because a 68 mm hole must be made in the partition wall for its installation and that of the trim grille.
2. Execute a 68 mm hole for the coupling pipe in the wall.
3. Screw the lower metal fitting to the wall at the required height. Remember that the lower part of the TRAILS6T will rest on this angle and that the coupling pipe has to pass through the hole. See Figure 3.
4. Check that the system is stable and then carry out the necessary connections and adjustments before installing the upper support.
5. Screw the upper support to the TRAILS6T with the supplied screws (Figure 3) and then screw it to the wall, leaving the loudspeaker resting on the lower support.
6. Secure the TRAILS6T to the lower support using the supplied screws.
7. Install the coupling bar and trim grille by passing it through the 68 mm hole. Push the bar towards the loudspeaker until the grille is flush with the wall.

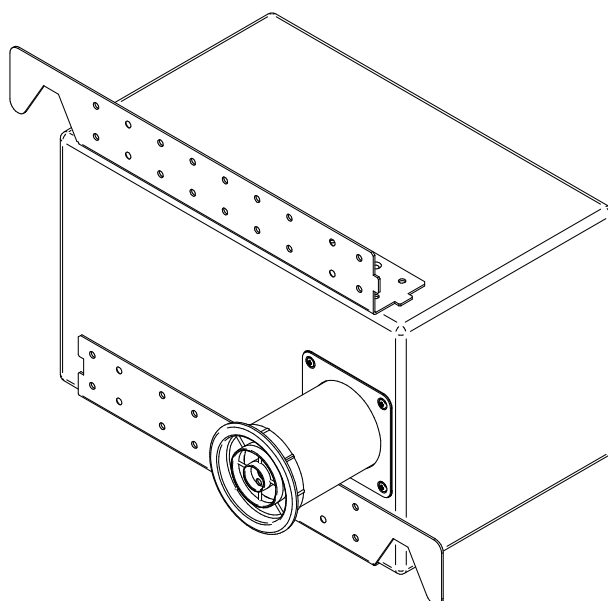

Figure 3: Diagram of installation in a partition wall

8. TECHNICAL SPECIFICATIONS

Driver	6.5-inch subwoofer
Nominal low impedance	8 Ω
RMS/Program power	60 Wrms / 120 W Program
Power selector (70/100V taps)	7.5/15/30/60 W
Sensitivity 1 W/1 m	86 dB
Maximum SPL @ 1m	106 dB
Frequency response (-10 dB)	50-260 Hz
LP Filter externally selectable	150 Hz / OFF
Connection type	Euroblock
Dimensions (W x D x H)	200 x 200 x 320 mm / 7.9 x 7.9 x 12.6 inches
Weight	6.5 kg / 14.3 lb

9. CONTENTS OF PACKAGING

- TRAILS6T
- Installation accessories: 4 metal fittings and 16 screws for securing on the loudspeaker
- Coupling bar
- Coupling bar trim grille
- Euroblock connector
- User's Quick Guide
- Warranty card



All product characteristics are subject to variation due to production tolerances. **NEEC AUDIO BARCELONA S.L.** reserves the right to make changes or improvements in the design or manufacturing that may affect these product specifications.

Motors, 166-168 08038 Barcelona - Spain - (+34) 932238403 information@ecler.es www.ecler.com